

# M203 and M240 DSCC Parts



**M240 Machine Gun**



**M240C Feed Tray**

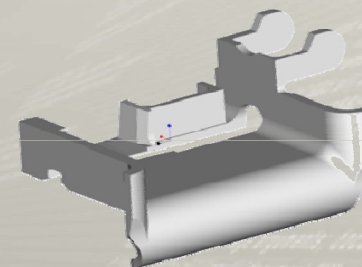

**M203 Grenade Launcher**



**Sear, M203**



# eSourcing Data



The Supplier Record maintains critical information on approval status, supplier capabilities, records of past project activity, etc

**Organizational Classification**

ORGANIZATION	APPROVAL STATUS	COUNTRY	STATE/REGION
Aerostructures	Pending Approval (PA)	UNITED STATES	California
Hill-Rom	Pending Approval (PA)	UNITED STATES	Indiana
TRW Automotive	Pending Approval (PA)	UNITED STATES	--

**Commodity Classification**

COMMODITY	CODE	TYPE
Blanking	--	Standard
Machining, CNC Center	--	Standard
Machining, High Precision	--	Standard
Sheet Metal, Stamping 500 to 1000 ton press	--	Standard
Stamping, Four Slide	--	Standard
Turnings, CNC	30019810	Standard

**Vendor Code Classification**

ORGANIZATION	VENDOR CODE	COUNTRY	STATE/REGION
TRW Automotive	TRW-09213-92	UNITED STATES	--

**Contact Information :**

Phone Number: 91 729 2252821 E-Mail: sales@caparoengg.com  
Fax Number: 91 729 2507300 Web Site URL: http://www.caparoengg.com

# Pilot TDP

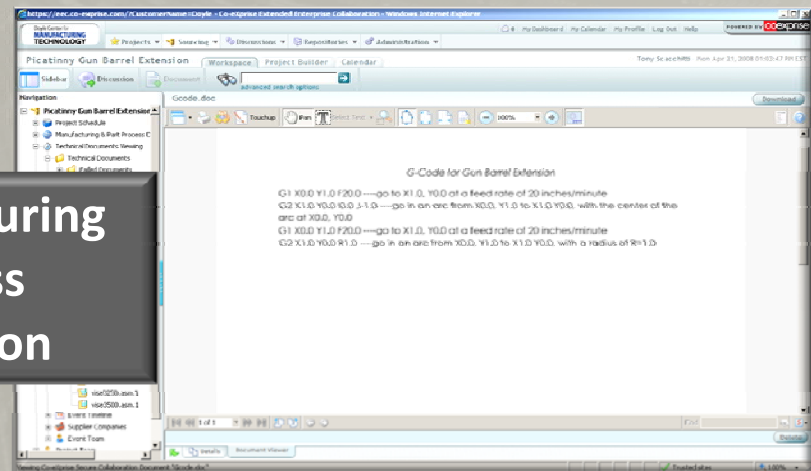
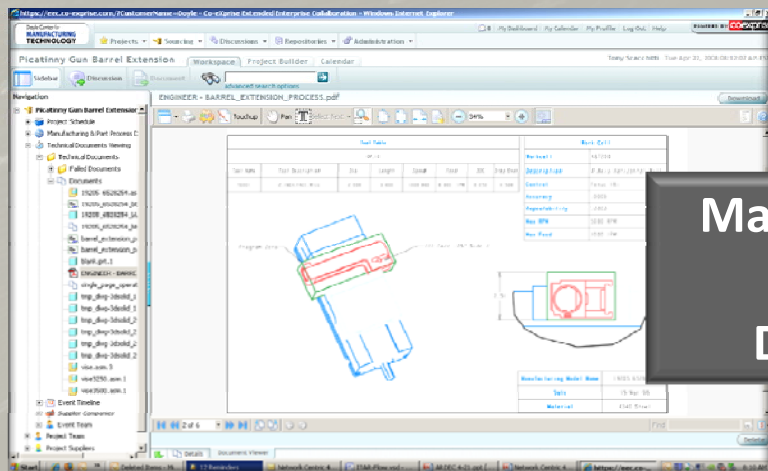
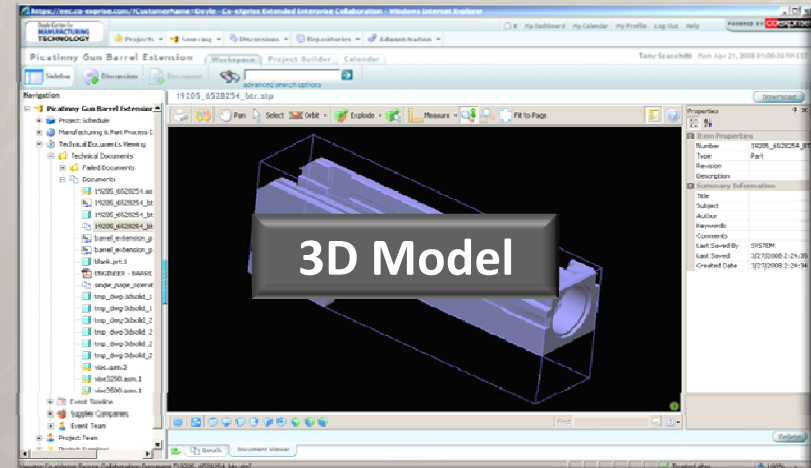
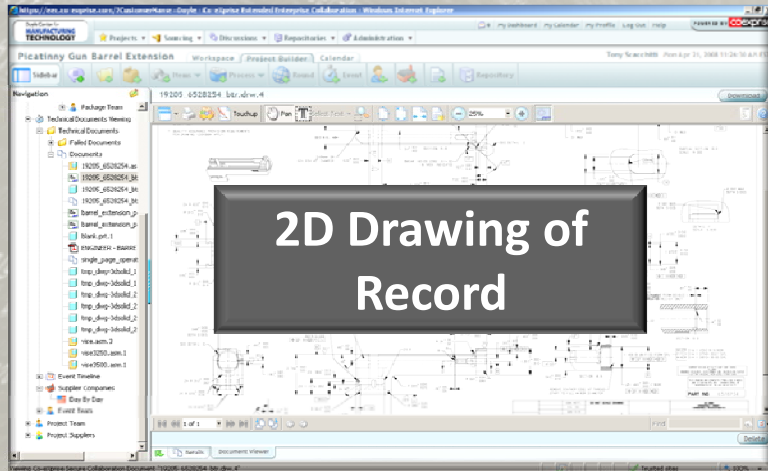

# Future State



- TDPs will be based on a fully annotated model with 2D views that are on demand printouts
- The eSourcing tool will be fully integrated with the design repository and financial systems for a seamless exchange of data
- There will be a data base of pre-certified suppliers
- Source selection tools will notify suppliers when a RFI or RFQ is ready for a response

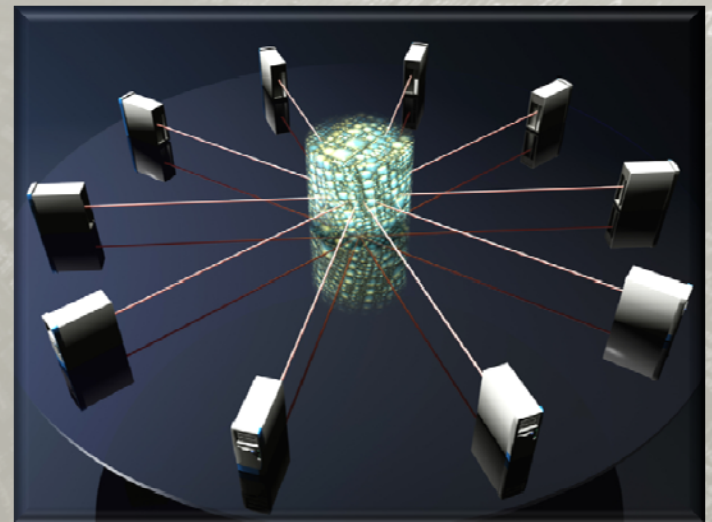

# Conclusions



- eSourcing will make it easier for both the DoD and the supply base to procure items
- The 3D TDP will help reduce the ambiguity found in traditional drawings
- In short, we will provide you what you need to do your job



# Questions

**MBE**  
Model Based Enterprise

